

## Output Ratings

Generating Set Model	MP45	MP50E
380 – 415V, 50 Hz	45.0KVA 36.0kW	50.0KVA 40.0kW



Ratings at 0.8 pf

## Ratings Definitions

### Prime Power – Model MP45

These ratings are applicable for supplying continuous electrical power (at variable load) in lieu of commercially purchased power. This model can supply 10% overload power for 1 hour in 12 hours.

### Standby Power – Model MP50E

These ratings are applicable for supplying continuous electrical power (at variable load) in the event of a utility power failure. No overload is permitted on these ratings. The alternator model is peak continuous rated (as defined in ISO 8528-3).

## Technical Data

Engine Make/Model:	Perkins 1103A-33TG1
Alternator Make/Model:	Leroy Somer LSA 42.3 M7
No. of Cylinders/Alignment:	3 in-line
Displacement: Litres (cu.in)	3.3 (201)
Bore and Stroke: mm (in)	105.0 (4.1) x 127.0 (5.0)
Compression ratio:	17.25:1
Induction:	Turbocharged
Frequency:	50 Hz
Engine Speed: (rpm)	1500
Gross Engine Standby Power: kW	46.5 (62.4)
Gross Engine Prime Power: kW	42.2 (56.6)
Radiator Coolant Capacity: Litres (US Gal)	10.2 (2.69)
Lubrication System Capacity: Litres (US Gal)	7.9 (2.09)
Fuel Tank Capacity: Litres (US Gal)	220 (58.1)
Fuel Consump, Prime : 1/hr (USg/hr)	10.7 (2.83)
Fuel Consump, Standby: 1/hr (USg/hr)	12.0 (3.17)
Heat Rejected to Exhaust System: kW (Btu/min)	35.0 (1992)
Heat Rejected to Water & Lube Oil: kW (Btu/min)	30.0 (1707)
Exhaust Temperature: °C (°F)	537 (999)
Combustion Air Flow: m3/min (cfm)	3.10 (109)



Your Partner In Power

## Overview

Standard reference conditions: 25deg C (77deg F) air inlet temperature, 152.4m (500feet) above sea level, 60% relative humidity. All engine performance data based on the above mentioned maximum continuous ratings. Fuel consumption data at full load for diesel fuel with specific gravity of 0.85 and conforming to BS2869: 1998, class A2.

Generating set pictured may include optional accessories.

Contact your local Marapco dealer for power ratings at specific site conditions.

Marapco Ltd

Tel / Fax : 0044 2893 355674

Website: www.marapco.com

N. Ireland - UK

In line with our policy of continuous product development, we reserve the right to change specification without notice.

# MP45/MP50E





Sound attenuated enclosures are manufactured from heavy gauge galvanised sheet steel (polyester powder painted for rust-proofed protection).

The enclosures are fitted with extra-thick, high-density acoustic grade foam for superior performance. Access is provided by wide aperture lockable doors with corrosion resistant fasteners used throughout.

The residential silencer is mounted internally for enhanced performance and heavy-duty lifting eyes are provided on the baseframe.

- ▶ Polyester powder coated baseframe with earth stud
- ▶ Vibration isolators between genset and base
- ▶ Fuel tank with filler cap
- ▶ Flexible fuel lines
- ▶ Fuel tank level gauge
- ▶ Fuel /water separator
- ▶ Exhaust Silencer with Exhaust manifold stub pipe
- ▶ Wiring loom /harness, 3-pole circuit breaker
- ▶ Battery rack and cables on base frame & Earth Strap
- ▶ Heavy duty starting battery /batteries (dry charged)
- ▶ Emergency stop lock-down pushbutton
- ▶ Operator's manual pack

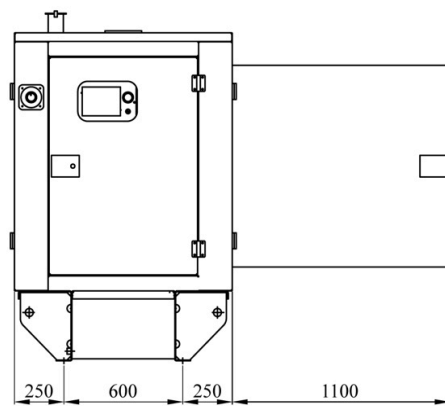
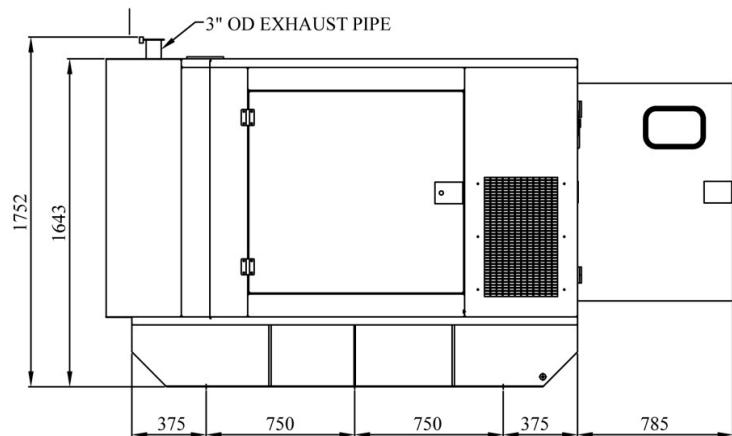

## Dimensions

	(mm)	(in)
Length	2,385	93.9
Height	1,643	64.7
Width	1,100	43.3
Total Height to Exhaust Rain Cap	1,752	69.0
Max. Horizontal Projection of Rear Door	785	30.9
Max. Horizontal Projection of Side Doors	1,100	43.3

## Sound Pressure Levels

	50Hz
15m, 75% Load: (dBA)	57.3
15m, 100% Load: (dBA)	57.8
7m, 75% Load: (dBA)	63.3
7m, 100% Load: (dBA)	63.8
1m, 75% Load: (dBA)	71.8
1m, 100% Load: (dBA)	72.5

## Weights

	(kg)	(lbs)	(kg)	(lbs)
Dry (with Lube Oil)	1,359	2,996		
			Wet (with Lube Oil and Coolant)	1,546 / 3,408

# MP45/MP50E

**Marapco Ltd**  
 Tel / Fax : 0044 2893 355674  
 Website: www.Marapco.com  
 N. Ireland - UK

