

## Output Ratings

Generating Set Model	MP500	MP550E
380 – 415V, 50 Hz	500.0 KVA	550.0 KVA
	400.0 kW	440.0 kW

Ratings at 0.8 pf

## Ratings Definitions

### Prime Power – Model MP500

These ratings are applicable for supplying continuous electrical power (at variable load) in lieu of commercially purchased power. This model can supply 10% overload power for 1 hour in 12 hours.

### Standby Power – Model MP550E

These ratings are applicable for supplying continuous electrical power (at variable load) in the event of a utility power failure. No overload is permitted on these ratings. The alternator model is peak continuous rated (as defined in ISO 8528-3).

## Technical Data

Engine Make/Model:	Perkins 2506A-E15TAG2
Alternator Make/Model:	Leroy Somer LSA47.2 M7
No. of Cylinders/Alignment:	6 in-line
Displacement: Litres (cu.in)	15.2 (927.6)
Bore and Stroke: mm (in)	137.0 (5.4) x 171.0 (6.7)
Compression ratio:	16.0:1
Induction:	Turbocharged & air-to-air charge-cooled
Frequency:	50 Hz
Engine Speed: (rpm)	1500
Gross Engine Standby Power: kW	495.0
Gross Engine Prime Power: kW	451.0
Radiator Coolant: Litres (US Gal)	58.0 (15.3)
Lubrication System Capacity: Litres	62.0
Fuel Tank Capacity: Litres (US Gal)	820.0 (216.6)
Fuel Consump, Prime : 1/hr (USg/hr)	100.0 (26.42)
Fuel Consump, Standby: 1/hr (USg/hr)	111.0 (29.32)
Heat Rejected to Exhaust System: kW (Btu/min)	398.0 (22634)
Heat Rejected to Water & Lube Oil: kW (Btu/min)	166.0 (9440)
Exhaust Temperature: °C (°F)	550.0 (1022)
Combustion Air Flow: M <sup>3</sup> /min (cfm)	36.6 (1293)

## Overview

Standard reference conditions: 25deg C (77deg F) air inlet temperature, 152.4m (500feet) above sea level, 60% relative humidity. All engine performance data based on the above mentioned maximum continuous ratings. Fuel consumption data at full load for diesel fuel with specific gravity of 0.85 and conforming to BS2869: 1998, class A2.

### Generating set pictured may include optional accessories.

Contact your local Marapco dealer for power ratings at specific site conditions.

### Marapco Ltd

Tel / Fax : 0044 2893 355674

Website: www.marapco.com

N. Ireland - UK

In line with our policy of continuous product development, we reserve the right to change specification without notice.



Your Partner In Power

## MP500/MP550E



## Sound Attenuated Enclosure: Features

Sound attenuated enclosures are manufactured from heavy gauge galvanised sheet steel (polyester powder painted for rust-proofed protection).

The enclosures are fitted with extra-thick, high-density acoustic grade foam for superior performance. Access is provided by wide aperture lockable doors with corrosion resistant fasteners used throughout.

The residential silencer is mounted internally for enhanced performance and heavy-duty lifting eyes are provided on the baseframe.

- ▶ Polyester powder coated baseframe with earth stud
- ▶ Vibration isolators between genset and base
- ▶ Fuel tank with filler cap
- ▶ Flexible fuel lines
- ▶ Fuel tank level gauge
- ▶ Fuel /water separator
- ▶ Exhaust Silencer with Exhaust manifold stub pipe
- ▶ Wiring loom /harness, 3-pole circuit breaker
- ▶ Battery rack and cables on base frame & Earth Strap
- ▶ Heavy duty starting battery /batteries (dry charged)
- ▶ Emergency stop lock-down pushbutton
- ▶ Operator's manual pack

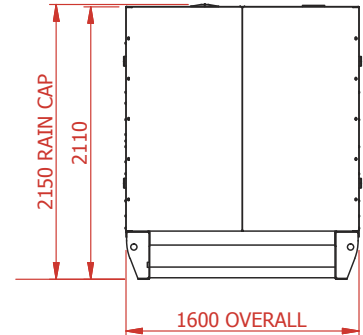
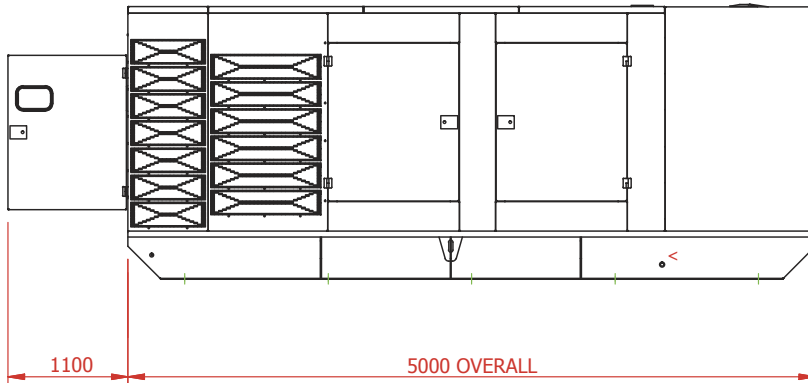

### Dimensions

	(mm)	(in)
Length	5,000	196.8
Height	2,110	83.0
Width	1,600	62.9
Total Height to Exhaust Rain Cap	2,150	84.6
Max. Horizontal Projection of Rear Door	1,100	43.3
Max. Horizontal Projection of Side Doors	1,100	43.6

### Sound Pressure Levels

	50Hz	60Hz
15m, 75% Load: (dBA)	70.8	73.1
15m, 100% Load: (dBA)	71.9	74.3
7m, 75% Load: (dBA)	76.8	79.3
7m, 100% Load: (dBA)	77.9	80.4
1m, 75% Load: (dBA)	83.8	86.5
1m, 100% Load: (dBA)	85.0	87.8

### Weights

	(kg)	(lbs)	(kg)	(lbs)
Dry (with Lube Oil)	5,500	12,125		
Wet (with Lube Oil and Coolant)			5,600	12,346

## MP500/MP550E

### Marapco Ltd

Tel / Fax : 0044 2893 355674

Website: www.Marapco.com

N. Ireland - UK

