

Smart String Inverter

SUN2000-42KTL



Smart

- 8 strings intelligent monitoring and fast trouble-shooting
- Power Line Communication (PLC) supported
- Smart I-V Curve Diagnosis supported

Efficient

- Max. efficiency 98.8%, European efficiency 98.6%
- 4 MPPTs for versatile adaptations to different layouts

Safe

- DC disconnect integrated, safe and convenient for maintenance
- Type II surge arresters for both DC and AC
- Residual Current Monitoring Unit (RCMU) integrated inside
- Fuse free design

Reliable

- Natural cooling technology
- Protection rating of IP65

Smart String Inverter (SUN2000-42KTL)



Technical Specifications	SUN2000-42KTL
	Efficiency
Max. Efficiency	98.8%
European Efficiency	98.6%
	Input
Max. Input Voltage	1,100 V
Max. Current per MPPT	22 A
Max. Short Circuit Current per MPPT	30 A
Start Voltage	250 V
MPPT Operating Voltage Range	200 V ~ 1000 V
Rated Input Voltage	720 V
Max. Number of Inputs	8
Number of MPP Trackers	4
	Output
Rated AC Active Power	42,000 W
Max. AC Apparent Power	47,000 VA
Max. AC Active Power (cosφ=1)	Default 47,000 W; 42,000 W optional in settings
Rated Output Voltage	480 V, 3W+PE
Rated AC Grid Frequency	50 Hz / 60 Hz
Rated Output Current	50.6 A
Max. Output Current	56.6 A
Adjustable Power Factor	0.8 LG ... 0.8 LD
Max. Total Harmonic Distortion	< 3%
	Protection
Input-side Disconnection Device	Yes
Anti-islanding Protection	Yes
AC Overcurrent Protection	Yes
DC Reverse-polarity Protection	Yes
PV-array String Fault Monitoring	Yes
DC Surge Arrester	Type II
AC Surge Arrester	Type II
Insulation Detection	Yes
Residual Current Monitoring Unit	Yes
	Communication
Display	LED Indicators, Bluetooth +APP
USB	Yes
RS485	Yes
PLC	Yes
	General
Dimensions(W x H x D)	930 x 550 x 283 mm (36.6 x 21.7 x 11.1 inches)
Weight (with mounting plate)	62 kg (136.7 lb.)
Operation Temperature Range	-25 °C ~ 60 °C (-13 °F ~ 140 °F)
Cooling	Natural Convection
Max. Operating Altitude	4,000 m (13,123 ft.)
Relative Humidity	0 ~ 100%
DC Connector	Amphenol Helios H4
AC Connector	Waterproof PG Terminal + OT Connector
Protection Rating	IP65
Topology	Transformerless
	Standard & Compliance <i>(more available upon request)</i>
Certificate	EN/IEC 62109-1, EN/IEC 62109-2, IEC62116
Grid Code	IEC 61727, G59/3, UTE C 15-712-1, CEI 0-16, CEI 0-21, RD661/2007, RD 1699/2011, RD 413/2014, PO 12.3, EN-50438-Turkey, EN-50438-Ireland, PEA, Resolution No.7, NRS 097-2-1

Efficiency Curve

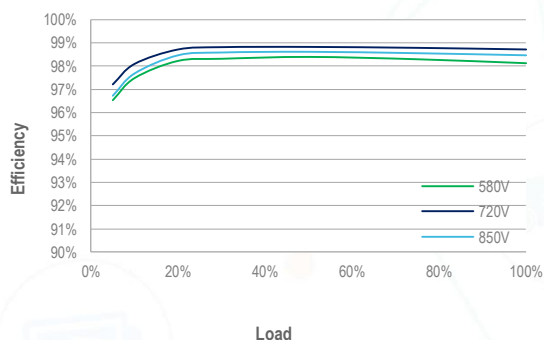

Circuit Diagram

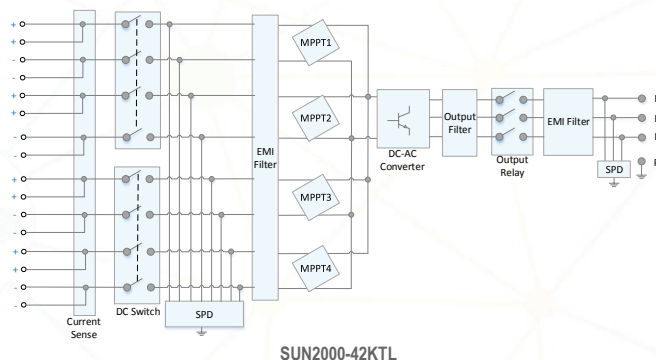

The text and figures reflect the current technical state at the time of printing. Subject to technical changes. Errors and omissions excepted. Huawei assumes no liability for mistakes or printing errors. For more information, please visit solar.huawei.com. Version No.01-(201806)