

Smart String Inverter

SUN2000-55KTL-HV-D1-001



Smart

- 8 strings intelligent monitoring and fast trouble-shooting
- Power Line Communication (PLC) supported
- Smart I-V Curve Diagnosis supported

Efficient

- Max. efficiency 99.0%
- European efficiency 98.8%
- 4 MPPT per unit, effectively reducing string mismatch

Safe

- DC switch integrated, safe and convenient for maintenance
- Residual Current Monitoring Unit (RCMU) integrated
- Fuse free design

Reliable

- Natural cooling technology
- Protection degree of IP65
- Type II surge arresters for both DC and AC

Smart String Inverter(SUN2000-55KTL-HV-D1-001)



Technical Specifications	SUN2000-55KTL-HV-D1-001
	Efficiency
Max. Efficiency	99.0%
European Efficiency	98.8%
	Input
Max. Input Voltage	1,500 V
Max. Current per MPPT	22 A
Max. Short Circuit Current per MPPT	30 A
Start Voltage	650 V
MPPT Operating Voltage Range	600 V ~ 1,450 V
Rated Input Voltage	1,080 V
Number of Inputs	8
Number of MPP Trackers	4
	Output
Rated AC Active Power	55,000 W
Max. AC Apparent Power	66,000 VA
Max. AC Active Power (cosφ=1)	66,000 W
Rated Output Voltage	800 V, 3W + PE
Rated AC Grid Frequency	50 Hz / 60 Hz
Rated Output Current	39.7 A
Max. Output Current	48 A
Adjustable Power Factor Range	0.8 LG ... 0.8 LD
Max. Total Harmonic Distortion	< 3%
	Protection
Input-side Disconnection Device	Yes
Anti-islanding Protection	Yes
AC Overcurrent Protection	Yes
DC Reverse-polarity Protection	Yes
PV-array String Fault Monitoring	Yes
DC Surge Arrester	Type II
AC Surge Arrester	Type II
DC Insulation Resistance Detection	Yes
Residual Current Monitoring Unit	Yes
	Communication
Display	LED Indicators, Bluetooth + APP
USB	Yes
RS485	Yes
PLC	Yes
	General
Dimensions (W x H x D)	930 x 600 x 270 mm (36.6 x 23.6 x 10.6 inch)
Weight (with mounting plate)	62kg (137lb.)
Operating Temperature Range	-25°C ~ 60°C (-13°F ~ 140°F)
Cooling Method	Natural Convection
Max. Operating Altitude	4,000m (13,123 ft.)
Relative Humidity	0 ~ 100%
DC Connector	Amphenol UTX
AC Connector	Waterproof PG Terminal + OT Connector
Protection Degree	IP65
Topology	Transformerless
	Standard Compliance (more available upon request)
Certificate	EN 62109-1/-2, IEC 62109-1/-2, EN 50530, IEC 62116, IEC 62910, IEC 60068, IEC 61683
Grid Code	IEC61727, G59/3, DEWA, IEEE 1547

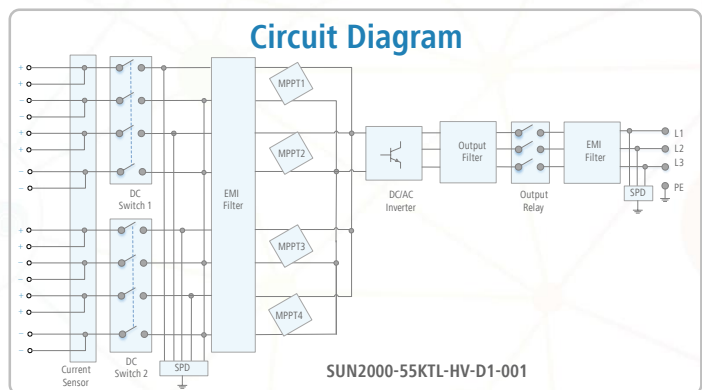
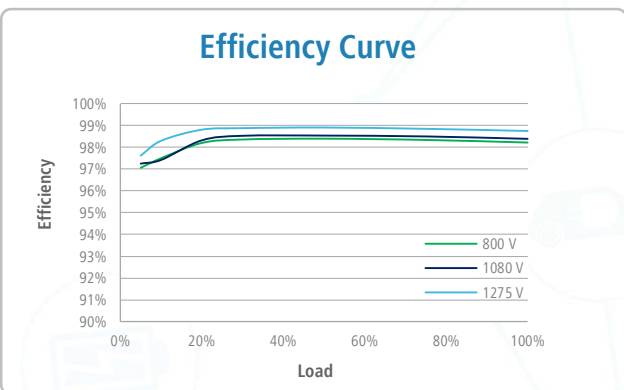

The text and figures reflect the current technical state at the time of printing. Subject to technical changes. Errors and omissions excepted. Huawei assumes no liability for mistakes or printing errors. For more information, please visit solar.huawei.com. Version No.01-(201807)